

Overshoot correction in digital-control system

by Y. KOREN, A. SHANI and J. BEN URI*

CONTROL SYSTEMS for machine tools are of two types, point-to-point and contouring. When designing a contouring-control system, it is important to minimize the overshoot on stopping of the cutting tool in order to keep it within the required accuracy limits (e.g., one pulse). In a closed-loop digital-control system, however, the reversal command is given only after the motor has traversed an arc equivalent to one pulse, so that the accuracy limit will have been exceeded. This drawback is remedied by means of a frequency divider in the feedback loop of the system; in addition, a decelerator for reducing motor-speed some time before stopping may be included.

Speed-control system

Fig. 1 shows a typical speed-control system for a d.c. motor. The bi-directional counter is fed two sequences of pulses through an input circuit, one as reference and the other from an optical or magnetic encoder. The counter correlates the two sequences and gives, through a d.-a. converter, a signal representing the position error of the system. The converter consists of weighted resistors and its voltage is adjusted to zero, by means of a special bias, for a counter reading of 100...0. The error signal is amplified and fed to the d.c. motor, and the direction circuit (fed two sequences of pulses, in quadrature, from the encoder) gives a signal instructing the motor to rotate in the direction of reduced error.

The input circuit directs the reference and feedback pulse sequences so that for one direction of rotation, the count will be increased by the reference and reduced by the feedback (or *vice versa*, for reversed rotation). In addition, it contains a circuit blocking the simultaneous appearance of pulses in both channels

(which would interfere with the counting), and another preventing reversal of the counter when full or empty. On receiving the stop command, the input circuit, in conjunction with the counter, applies damping to the system.

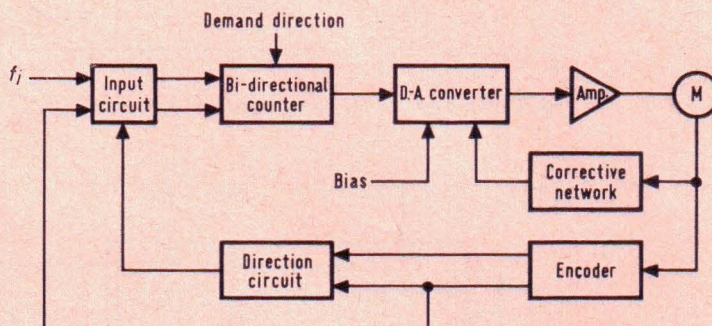

Fig. 1 Typical speed-control system

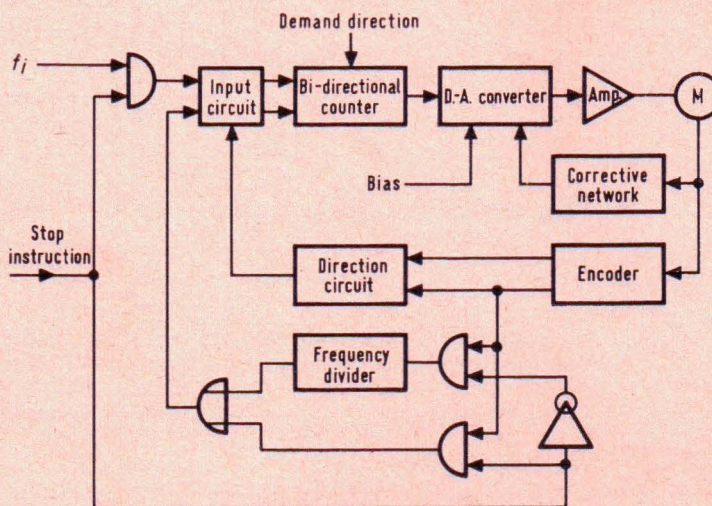

Fig. 2 Speed-control system with frequency divider

* This paper is part of Y. Koren's M.Sc. thesis; Prof. J. Ben Uri and Dr. A. Shani acted as his thesis advisers. The authors are with the Faculty of Electrical Engineering, Technion—Israel Institute of Technology, Haifa, Israel.



Y. Koren is with Technion—Israel Institute of Technology, where he graduated in 1965, received his M.Sc. in 1968 and where he is, at present, a teaching assistant, while carrying out research towards his D.Sc. degree in the area of numerical control for machine tools. He is also interested in digital control and quantization problems.



A. Shani graduated from the München Institute of Technology in 1948. He received the M.Sc. and D.Sc. degrees from Technion—Israel Institute of Technology in 1956 and 1958, respectively. Between 1958 and 1960 he was Research Associate with Elliott Brothers, London. From 1960 to 1965 he headed the computer group and electronic division of the Scientific Department, Ministry of Defence, Israel. At present he is

technical director of Elbit Computers Company, Haifa, and part-time senior lecturer at Technion. He was the first chairman of the Israel National Committee of Automatic Control (Ifac) during 1965–1966.



J. Ben Uri graduated from the Technische Hochschule, Darmstadt, Germany, in 1930, and received the Dr. Ing. degree in 1931. He then joined the City and Guilds College, London, England. He emigrated to Israel in 1934, where he worked as a consulting engineer and was manager and chief engineer of the Shell Butagaz Company. He became Controller of Electrical Industries in the New Israeli Ministry in 1948. He was manager and chief

engineer of Ramlah Motor Company and Telrad-Telephone Company, Lydda, Israel. He held a part-time teaching position at the Israel Institute of Technology, Haifa, in 1952, and was a visiting professor at the Carnegie Institute of Technology, Pittsburgh, in 1958. He returned to Israel in 1960 where, at present, he is a professor in the Israel Institute of Technology. His main interests are in the fields of electrical drives and the application of semiconductors to them in servo-systems and automation. Professor Ben Uri is a member of the Swiss Association of Electrical Engineers, Zurich, and F.I.E.E.

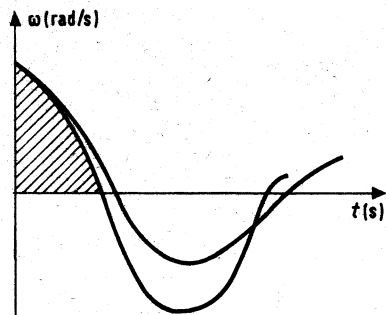

Fig. 3 Time response for two gains

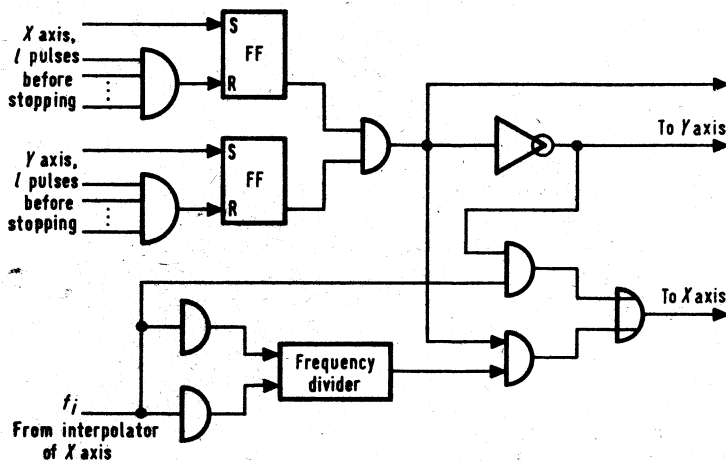

Fig. 4 Decelerator circuit

The open-loop gain of the system should be high for several reasons, but mainly in order to reduce the number of counter stages. The latter (including one stage serving as sign bit) is calculated from—

$$2^{i-1} = c f_{max}/K \quad (1)$$

where i = number of stages, f_{max} = maximum input frequency, K = open-loop gain of system, and c = constant depending on system overshoot ($c > 1$).

Another advantage of a high gain is a reduction in position error. Under fixed advance of the axes in a contouring-control system, a position error in each axis does not entail a path error but, when the combined movement is circular or parabolic, a path error will result; being proportional to $1/K^2$, it accounts for the need for high gain in high-accuracy systems. Obviously, load torque disturbances also decrease with increasing gain. However, high gain renders the system unstable and necessitates a corrective network giving a voltage proportional to acceleration.

Frequency divider

Under normal conditions, the frequency divider receives the pulses from the encoder, and delivers the frequency obtained divided by 2^n (n being the number of its stages), which is then fed to the appropriate channel of the counter. On receiving a 'stop' command, the frequency divider is short-circuited and the pulses are fed directly to the counter circuits.

The frequency divider actually reduces the number of pulses/revolution drawn from the encoder. The table accuracy required, is a length unit (say 0.01 mm) equivalent (by means of an appropriate gear-box) to one pulse at the frequency divider output. In these circumstances, the overshoot following a stop command, must not exceed one pulse. On the other hand, if the system was not modified, the motor would continue to rotate by inertia, so that the first notice of an overshoot (and of the need for a suitable command) would be received by the system only after an arc equivalent to one pulse had been traversed. For this

reason, the frequency divider is used for normal operation only, and its exclusion on receiving a stop command implies that 2^n pulses will now be equivalent to one original pulse. In other words, an error up to 2^n pulses is permissible without detriment to accuracy.

The use of the frequency divider entails two additional advantages. As can be seen from fig. 3, the error due to overshoot on stopping (represented by the hatched area) can be reduced by increasing the system gain. Exclusion of the frequency divider increases the gain 2^n -fold only after compliance with a position command, so that normally the system works at a lower gain and is more stable. Furthermore, position commands in machine-tool control systems are usually based on an incremental technique and this entails a cumulative error. The single-pulse accuracy requirement is equivalent to the 2^n -th part of the basic length unit of the system so that, at worst, an error of one length unit only, can accumulate after 2^n operations.

The number of stages of the frequency divider is connected with that of the counter. For the real position error on stopping to vanish, the counter must not be allowed to become either full or empty. In other words—

$$i - 1 \geq n \quad (2)$$

It should be noted that the open-loop gain of the system on receiving a stop command (K_s) is obtainable from the above requirement. Equ. 1 then yields—

$$2^{i-1} = c \cdot \frac{f_{max} 2^n}{K_s} \quad (3)$$

Substituting (2) in (3), we have—

$$K_s \geq c f_{max} \quad (4)$$

and, since $c > 1$,

$$K_s > f_{max} \quad (5)$$

Decelerator

At high working speeds, the frequency divider does not provide a complete solution to the overshoot problem; hence the speed should be reduced prior to stopping. In biaxial point-to-point control systems, the solution is simple: reduction of the speed of each axis to a constant low level a certain distance before stopping. This, however, is not feasible in contouring-control systems, as the axes are assigned different working speeds and reduction of both to the same constant level would affect the path before stopping. The only solution possible in this case, is proportionate reduction, and a suitable circuit for this purpose is shown in fig. 4. The controlled motor rotates at a speed proportional to the input frequency f_i , generally originating in a d.d.a. interpolator. When the axis working at the higher speed reaches a position l pulses before the stop, both axes are slowed down 2^m -fold (m denoting the number of stages of the frequency divider of the decelerator), and a path error is prevented.

By linearizing the speed-control system it can be shown to be of second order, with the frequency as input and the motor speed as output. In this system the first overshoot of the path is obtainable as—

$$d = \frac{f_i}{n} \exp a \quad (6)$$

when—

$$a = - \frac{\pi - t_d^{-1} \sqrt{(1 - \zeta^2)}}{\zeta} \\ \frac{\sqrt{(1 - \zeta^2)}}{\zeta}$$

f_i = input frequency
 n = natural frequency of system
 ζ = damping factor.

Equ. 6 shows that the first overshoot is linear with the input frequency and decreases in the same proportion.